

TRENCH DRAIN AND GRATING COLOURS

- WHITE
 - BLACK
 - GREY
- TRENCH CHANNEL LENGTHS - 10'
 - 2" DROPOUTS ARE RECOMMENDED EVERY 10' (INDOOR) AND EVERY 8' (OUTDOOR)
 - GRATING BY EMCO, 2 3/8" (60mm) WIDE BY 7/8" (22mm) DEEP
 - EXTRUDED PVC TRENCH IS UV STABLEIZED

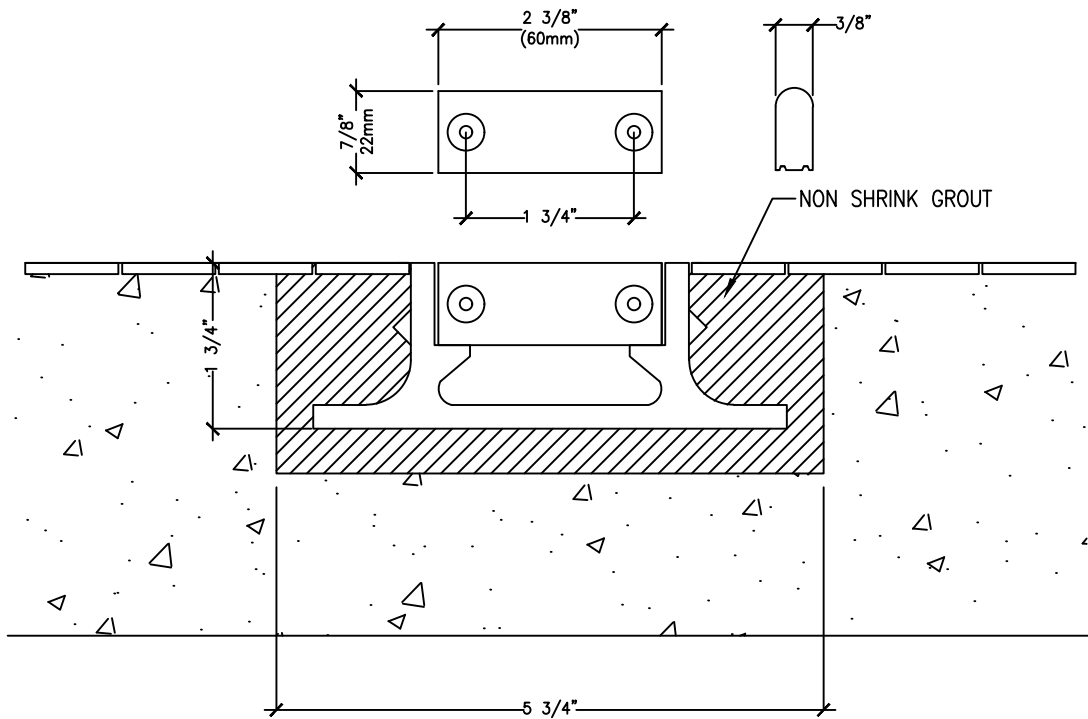

TYPICAL INSTALLATION

- PROVIDE 5-3/4" WIDE, 2-1/4" DEEP BLOCK OUT FOR TRENCH DRAIN BODY INSTALLATION
- GROUT TRENCH DRAIN BODY IN PLACE WITH NON SHRINK GROUT
- PROVIDE A 2-3/8" SPACER BOARD IN THE TRENCH TO ENSURE THE TRENCH DRAIN WIDTH, AND TO KEEP IT FREE OF DEBRIS.
- 2" DROPOUTS TO BE INSTALLED EVERY 10'(INDOOR) OR 8' (OUTDOOR), CONNECTED TO SANITARY.
- DROPOUTS TO BE EITHER 1-1/2" OR 2" PIPE.
- ALL DROP SECTIONS AND CORNERS ARE TO BE BUTT FIT.
- USE A HOLE SAW TO CUT THE BOTTOM OF THE TROUGH OVER THE DROPOUT PIPE, AND CUT THE DROPOUT PIPE FLUSH WITH THE BOTTOM OF THE TROUGH AFTER THE TROUGH IS GROUTED IN PLACE.
- APPLY WELDON 810 EPOXY AROUND THE DROPOUT PIPE AND THE TROUGH TO SEAL THE JOINT.
- APPLY A THIN COAT OF WELDON 810 EPOXY AT EACH BUTT JOINT WITH A 1" PUTTY KNIFE, TO FILL IN THE JOINT AFTER THE TROUGH HAS BEEN GROUTED IN PLACE.
- INSTALL THE GRATING WITH THE SQUARE EDGE DOWN (ROUNDED SURFACE UP)
- CUT LENGTH OF GRATING AS REQUIRED.

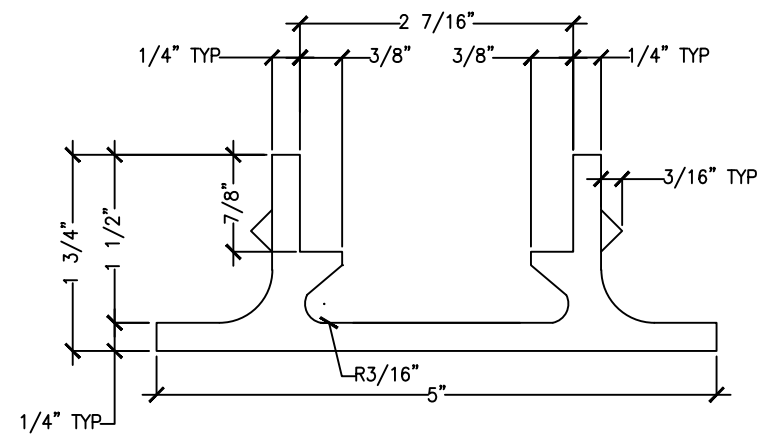
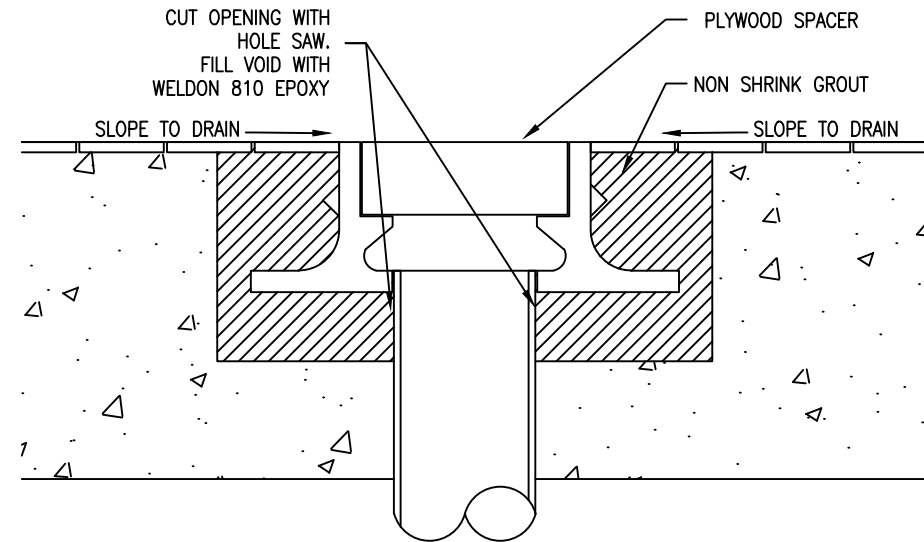

TRENCH DRAIN BODY

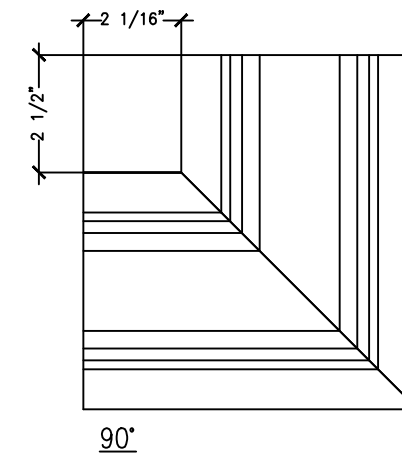

90°

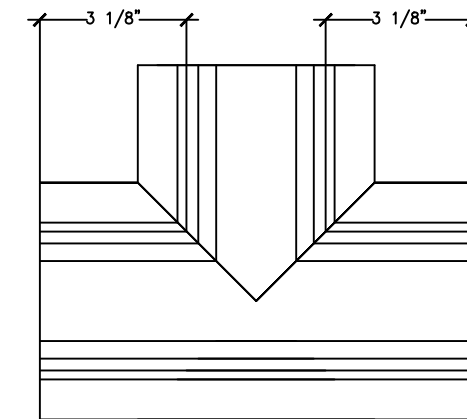

TEE

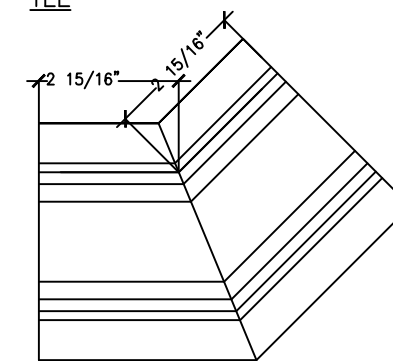

45° ANGLE

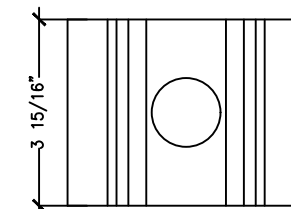

DROP-OUTS

PART NUMBERS:

- CHANNEL - KBE-C-W
- 90° - KBE-90-W
- 45° - KBE-45-W
- TEE - KBE-T-W
- DROPOUT - KBE-D-W
- GRATE - KBE-3-W
- GRATE 90° - KBE-3-90-W
- GRATE 45° - KBE-3-45-W
- GRATE TEE - KBE-3-T-W
- EPOXY SEALER - KBE-E-810

- WHITE - W
- BLACK - B
- GREY - G

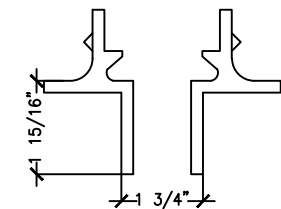

REVISIONS:

PROJECT:	SCALE: N.T.S.
	DATE: 06-01-2025
DRAWING TITLE:	DRAWN BY: KV
KBE TRENCH DRAIN	PROJECT NO.:
	DRAWING NO.:

